



INSTRUKCJA ORYGINALNA 2/3 Zasady montażu i użytkowania

ORIGINAL INSTRUCTIONS 2/3 Installation and user manual

ORIGINÁLNÍ NÁVOD 2/3 Pravidla pro instalaci a použití

VML Electro 230

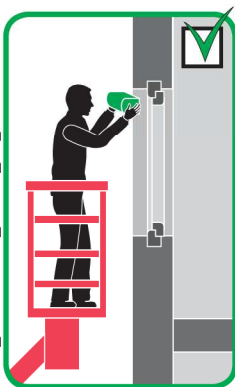
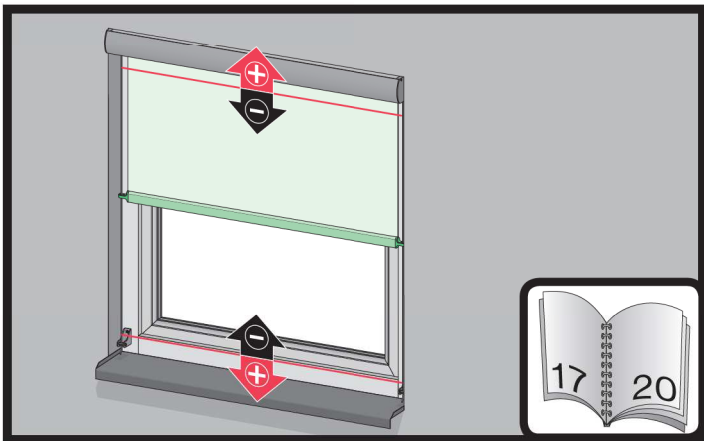
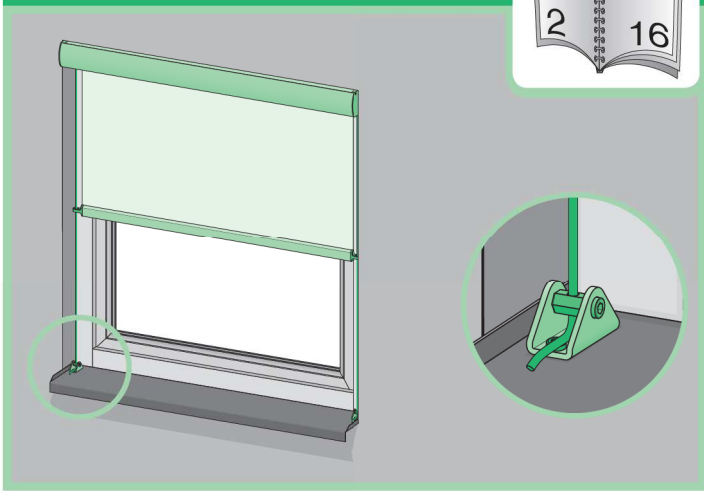
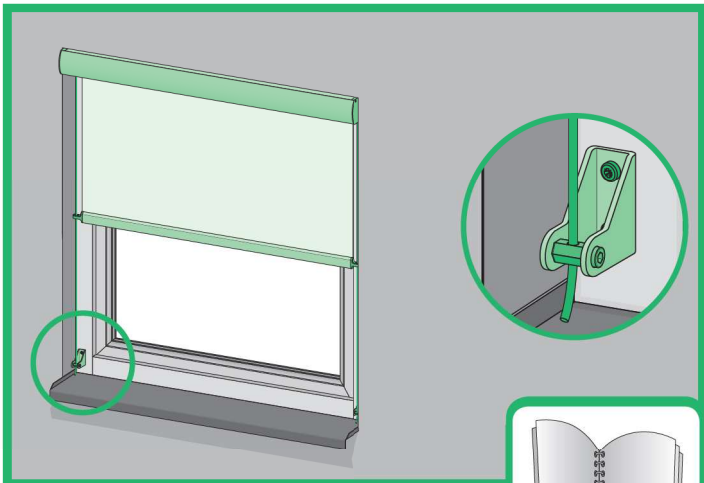

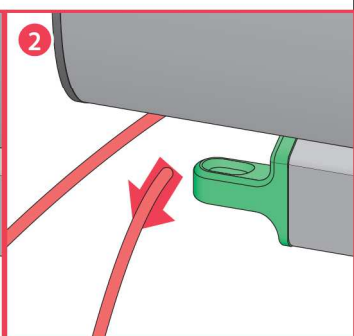
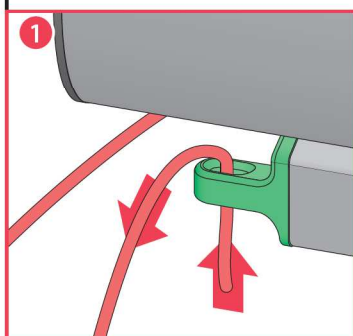
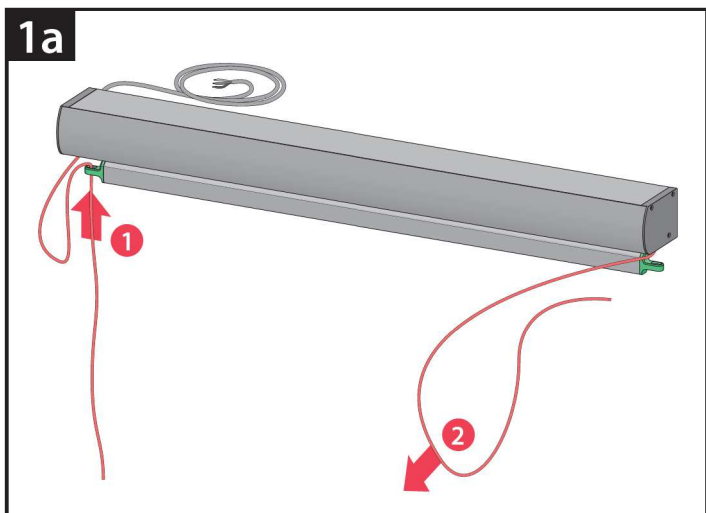
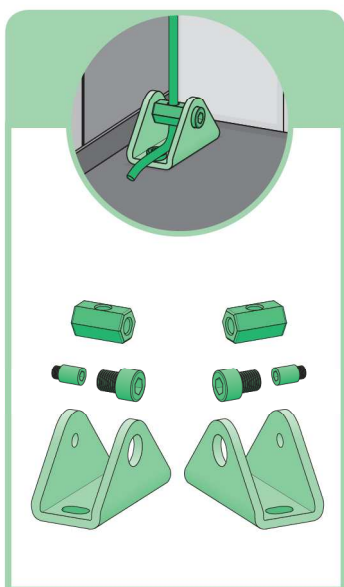
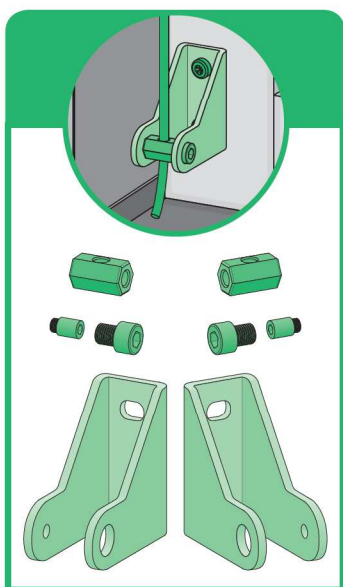
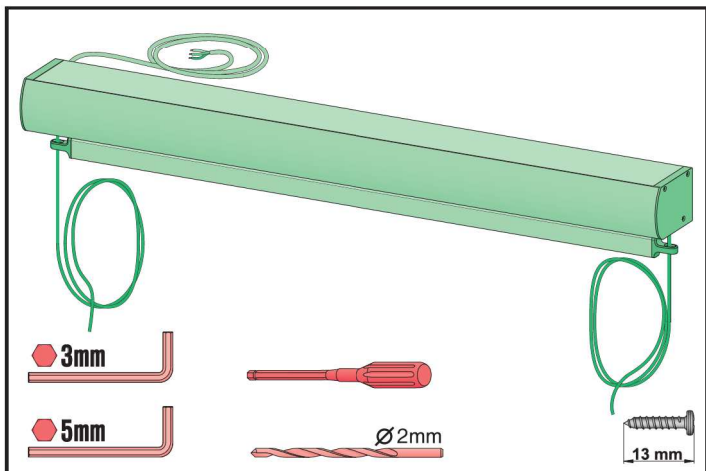
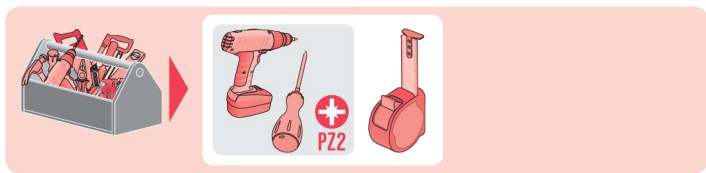

1b

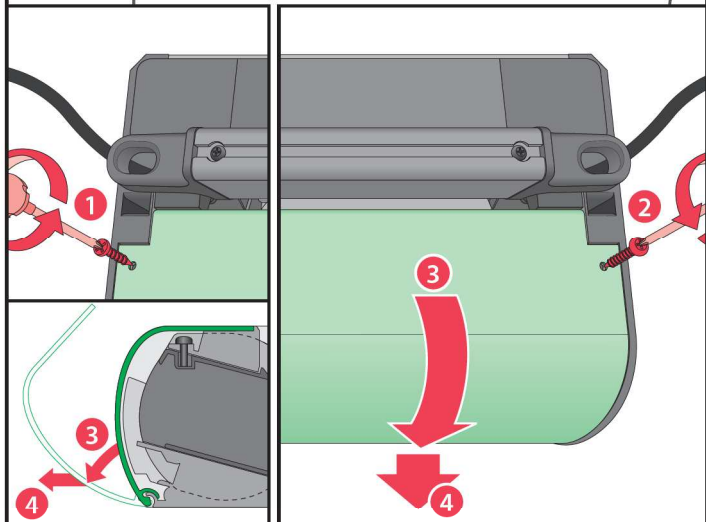
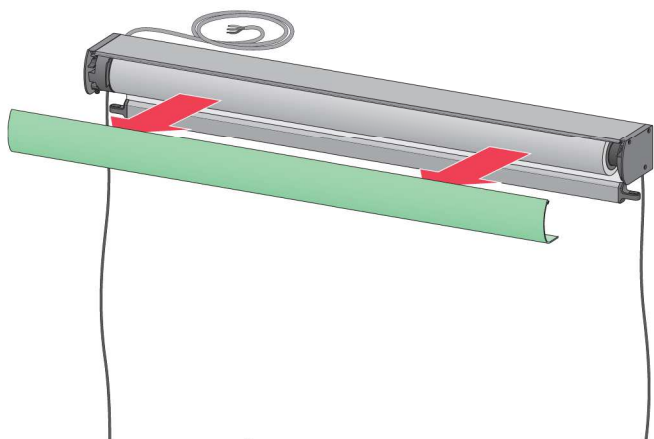

1c

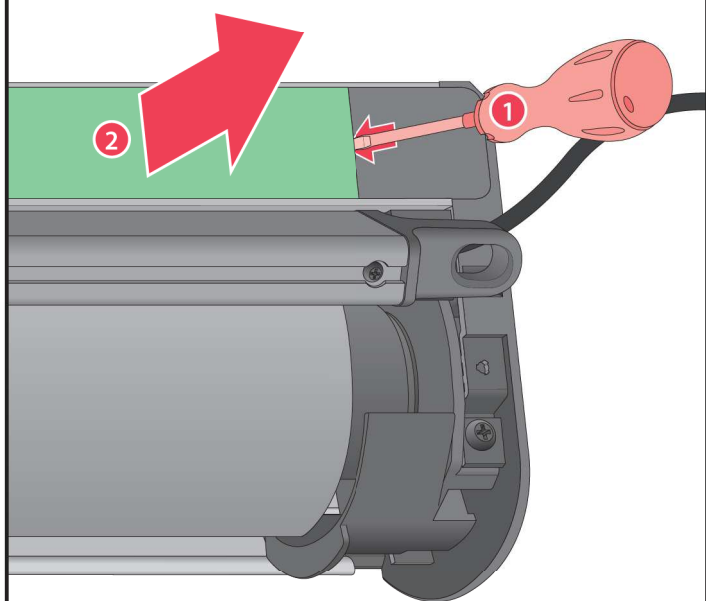

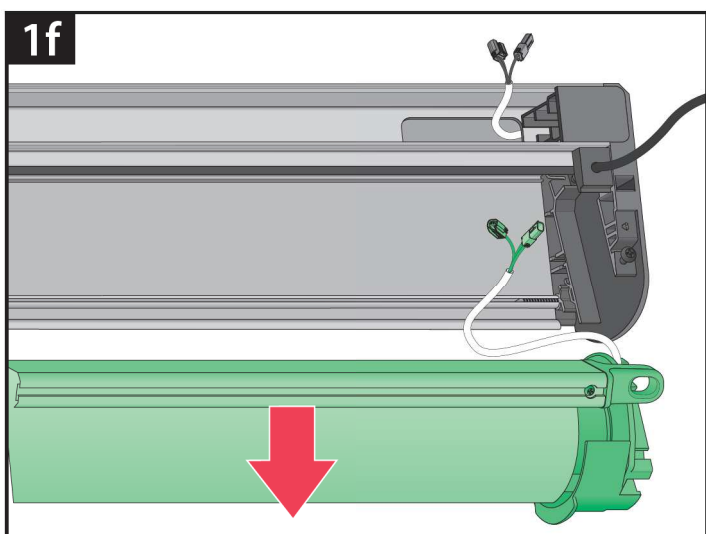
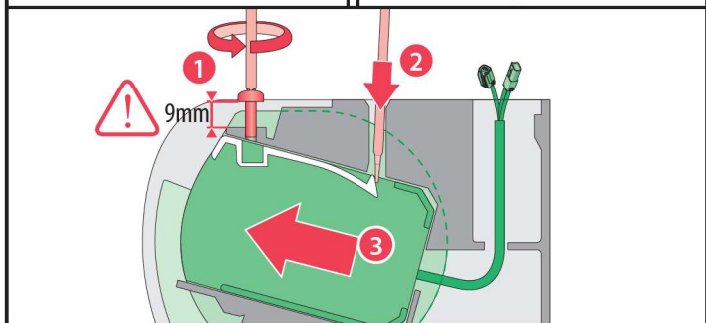
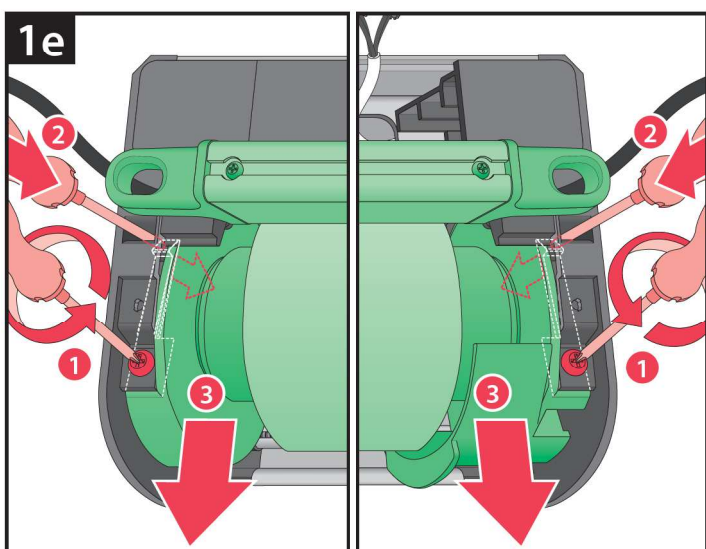
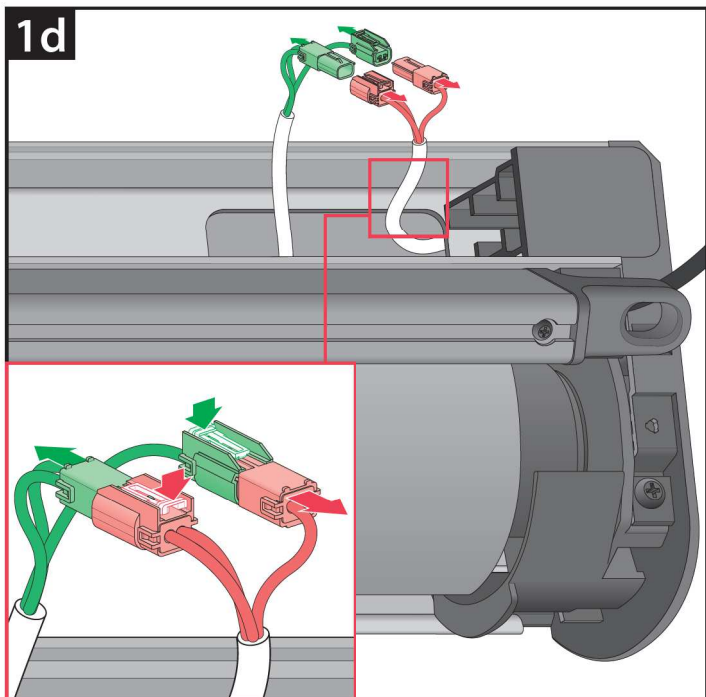

2a

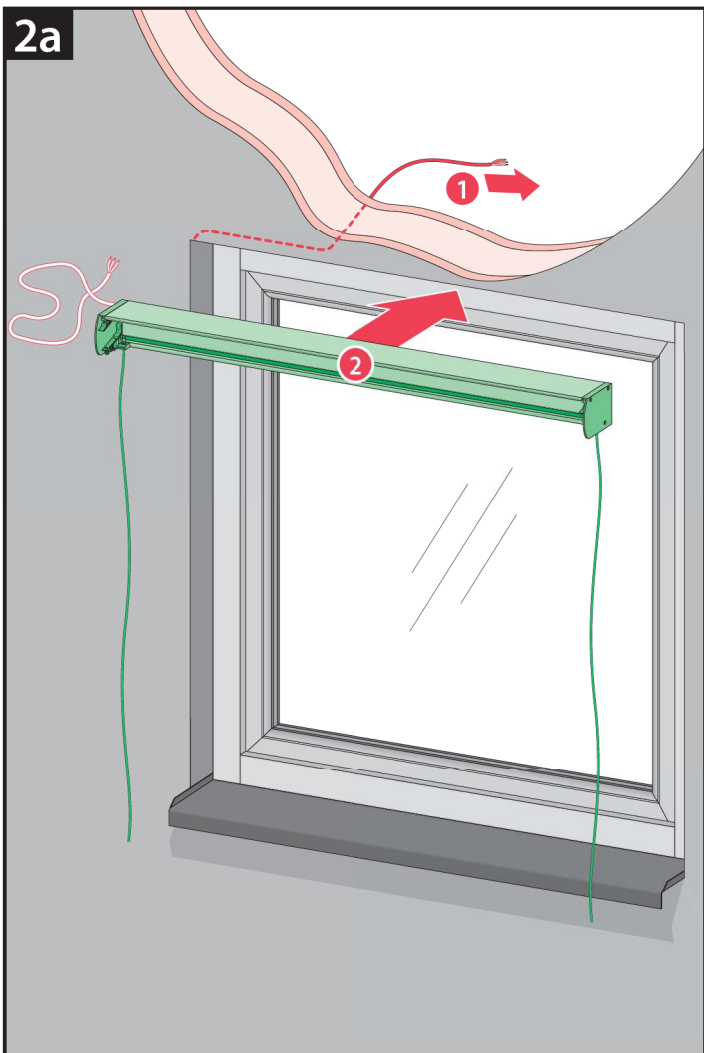

2b

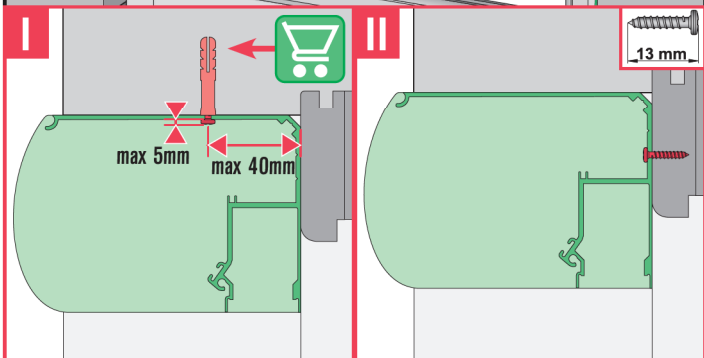
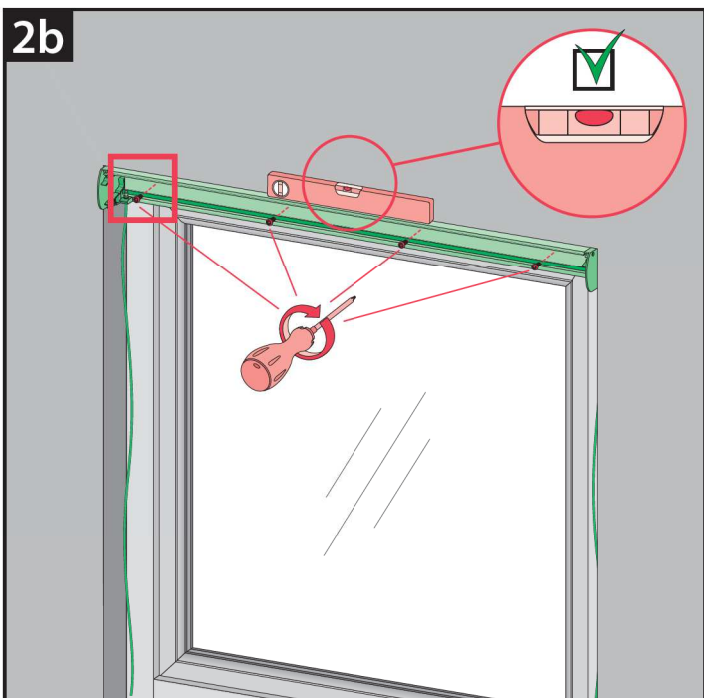

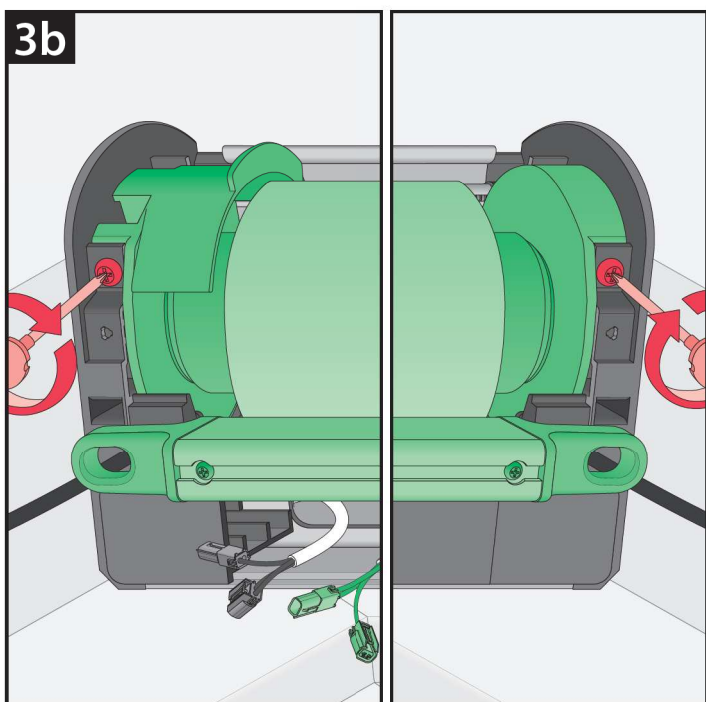
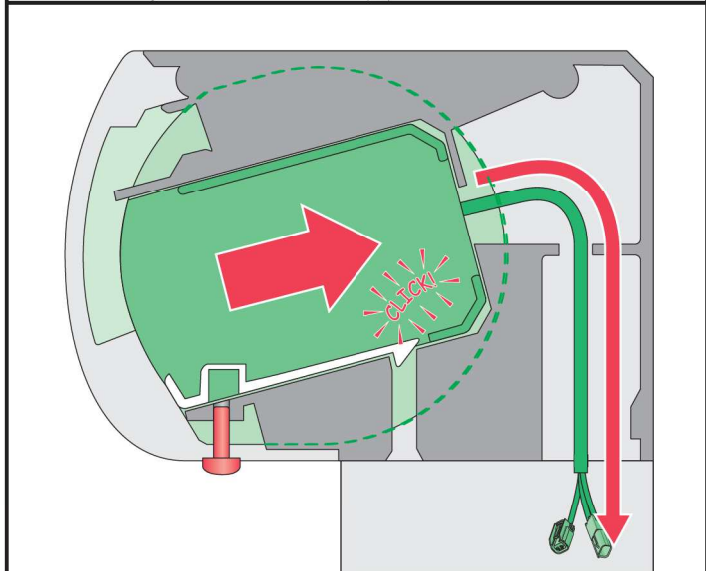
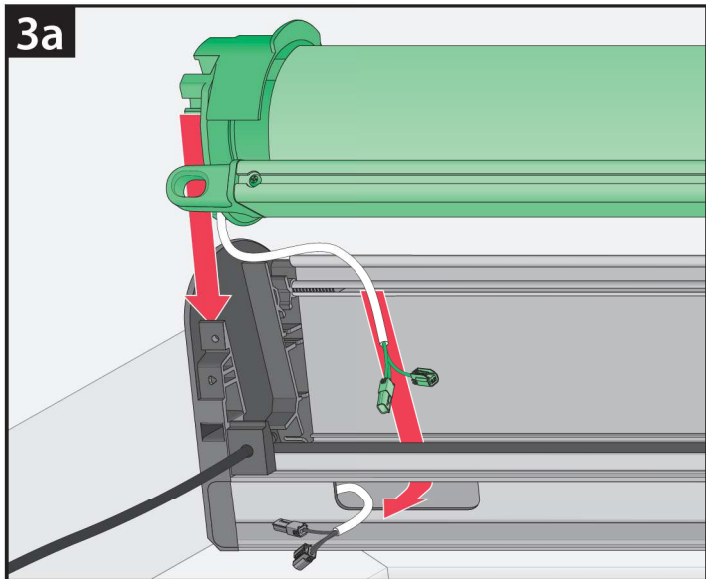
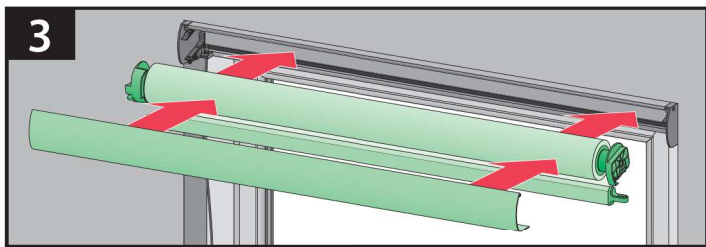

3c

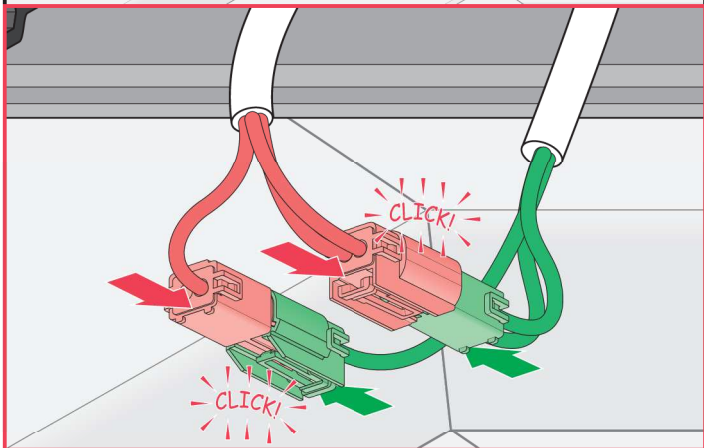
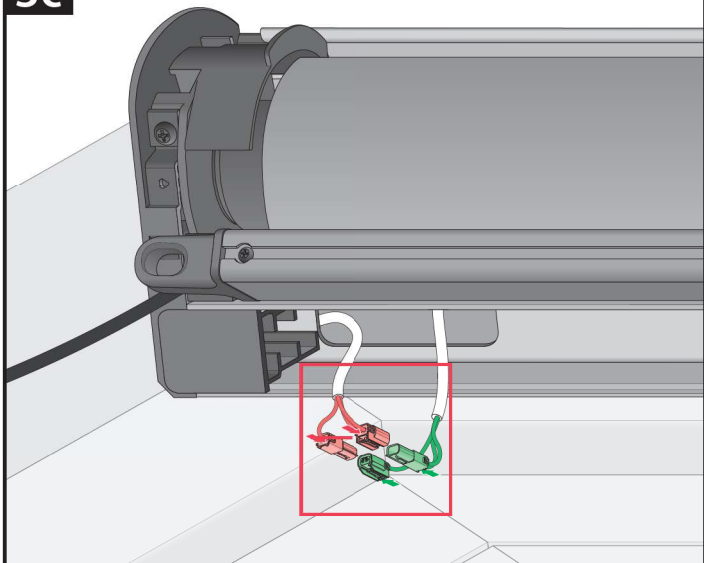

3d

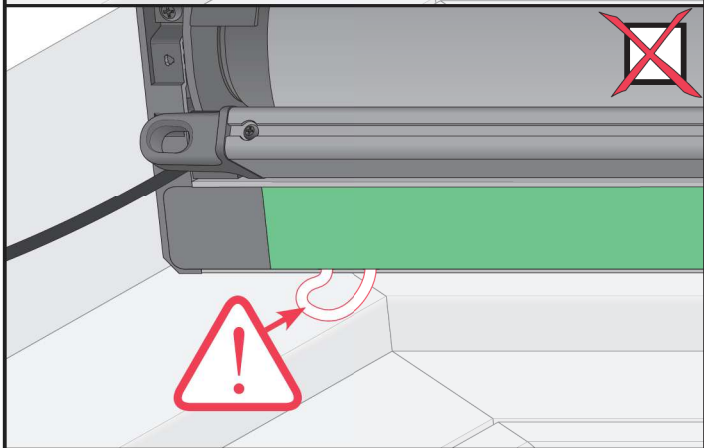
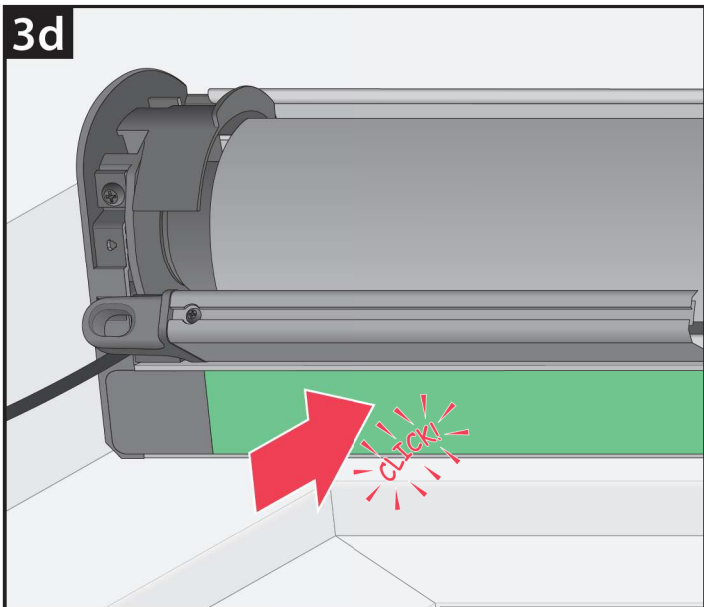

3e

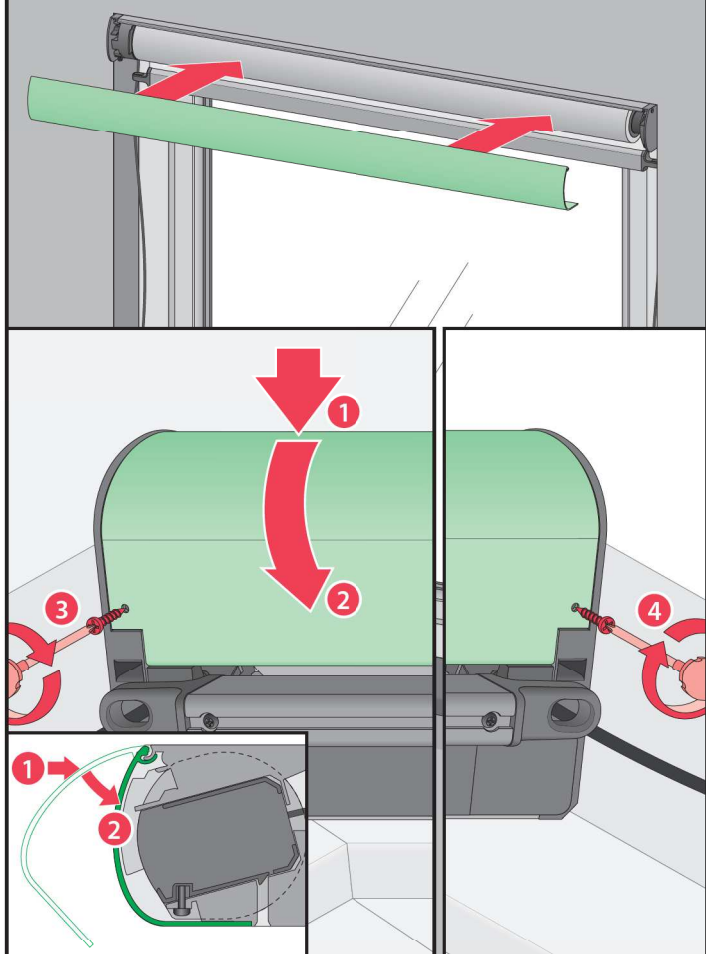

4

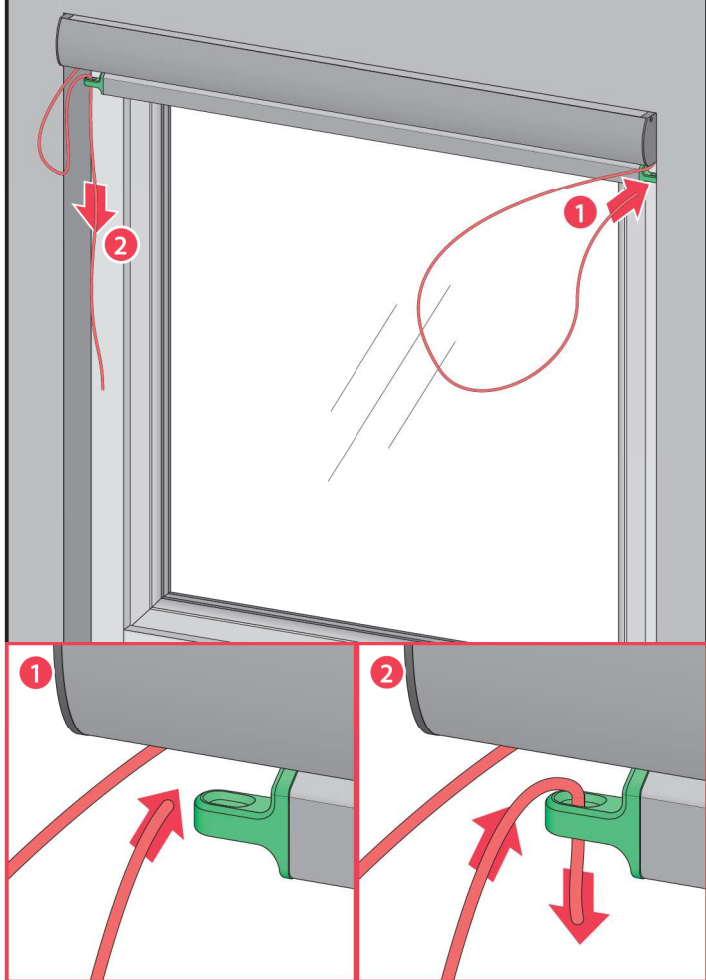

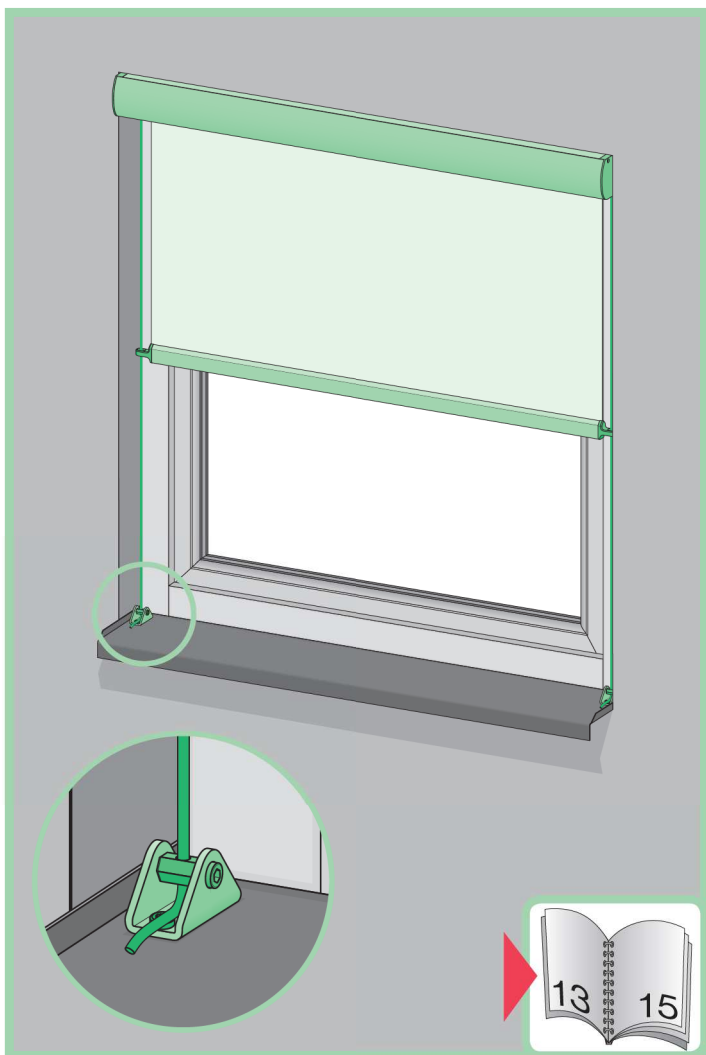
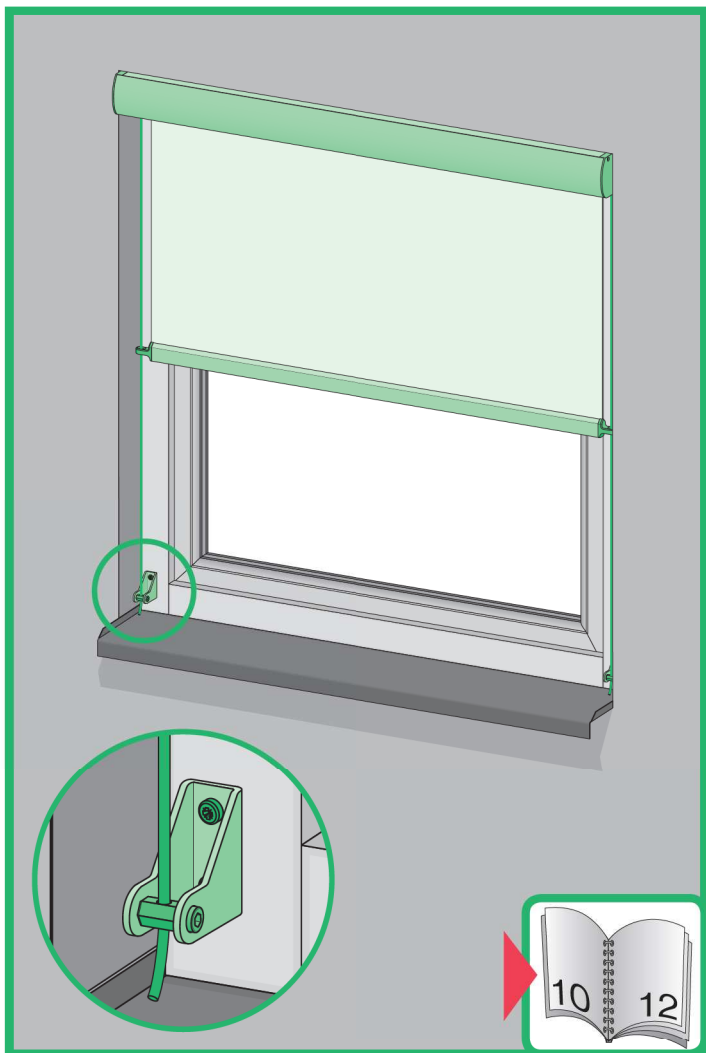

5

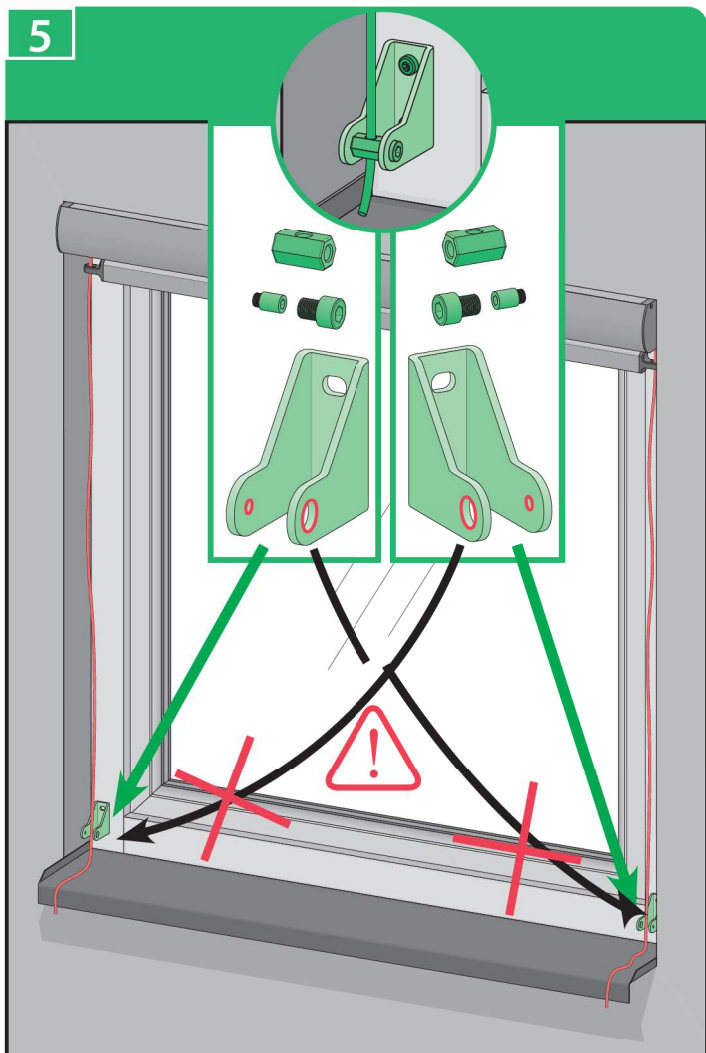

5a

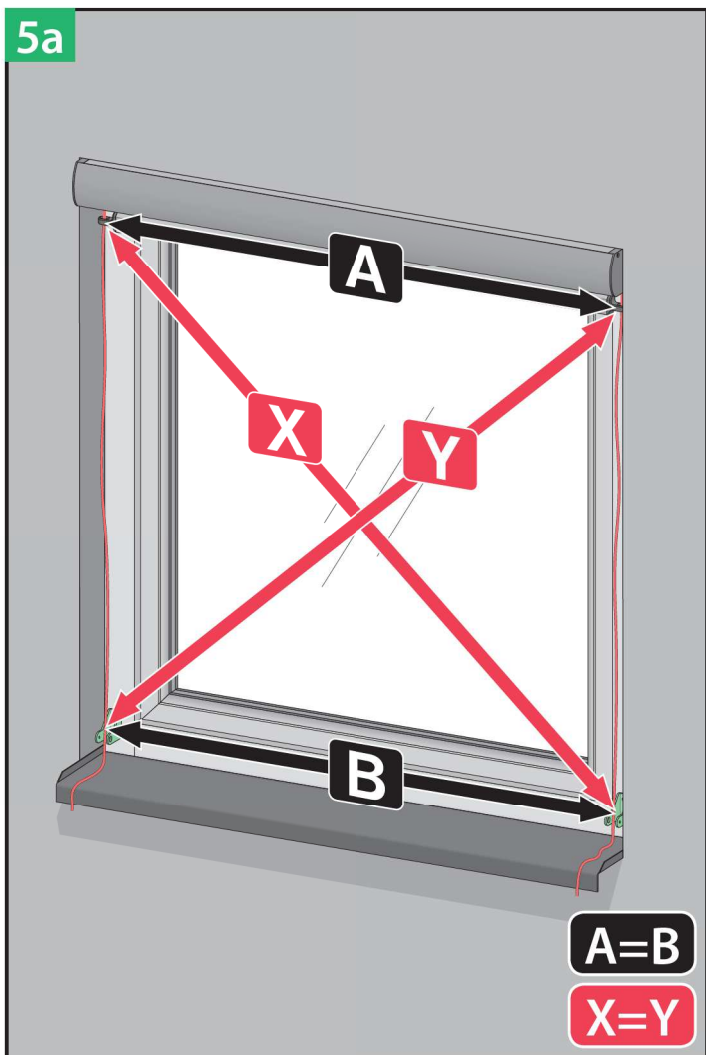

5b

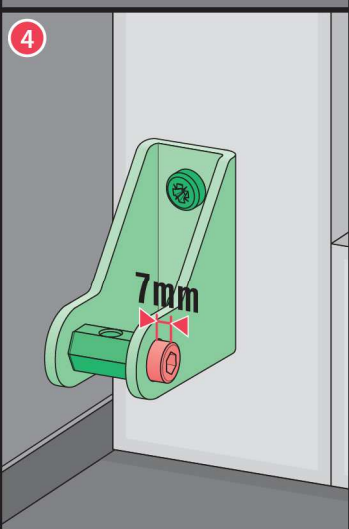
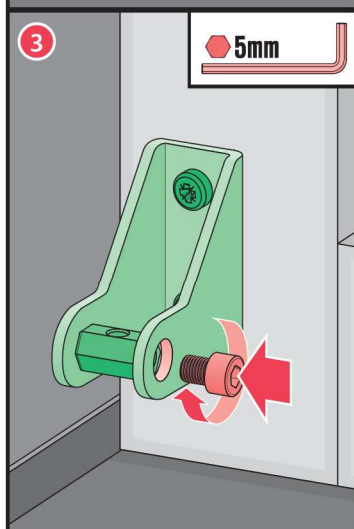
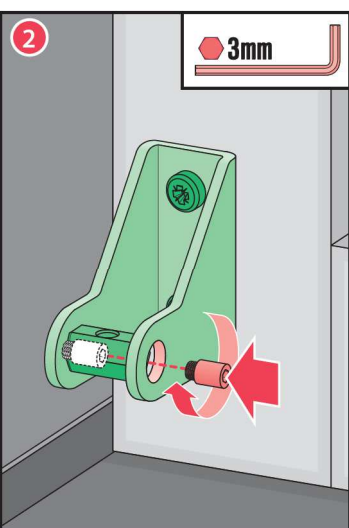
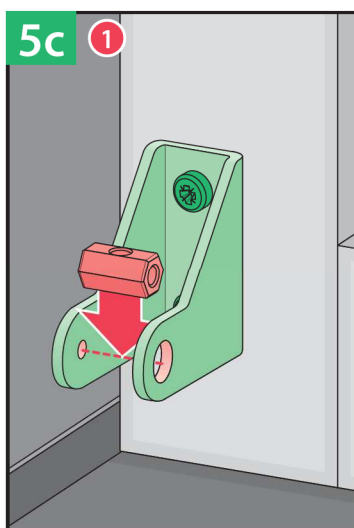
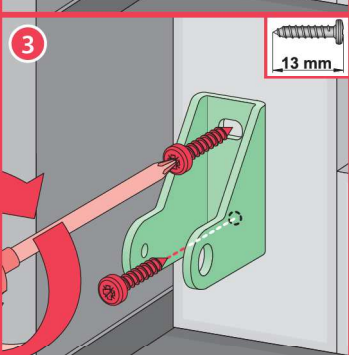
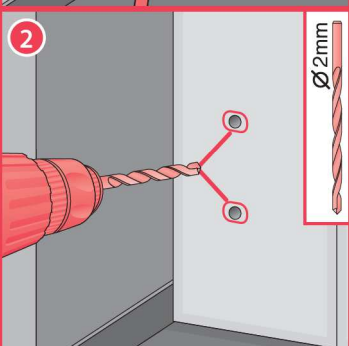
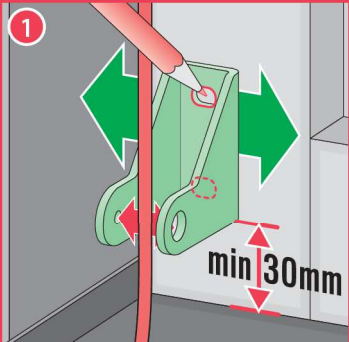

5

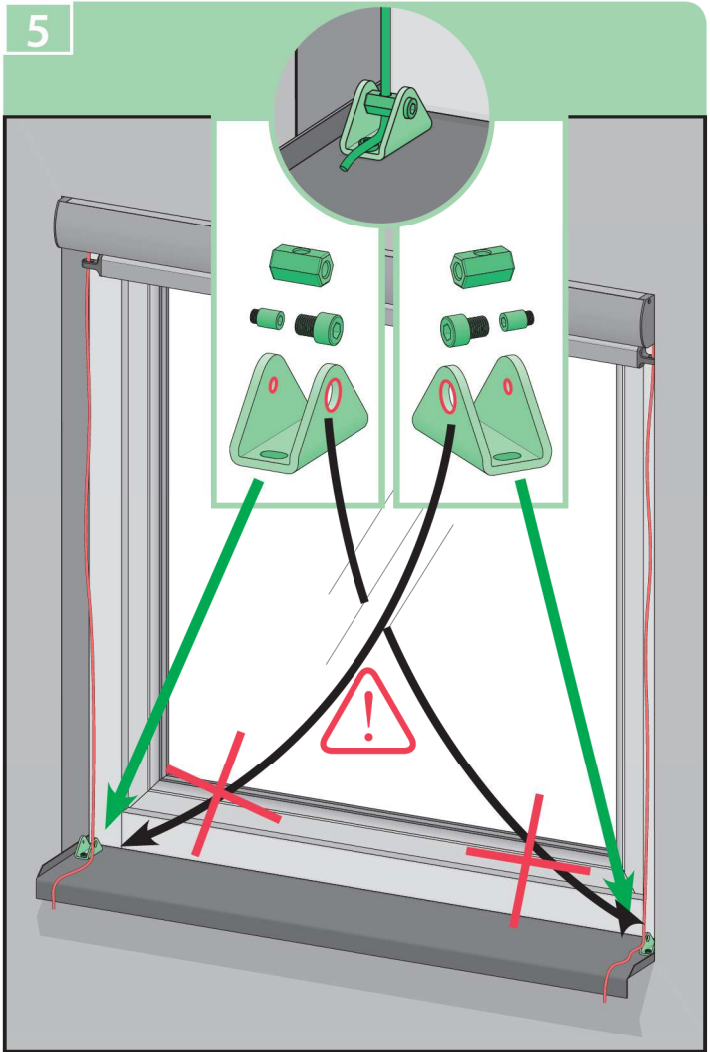

5a

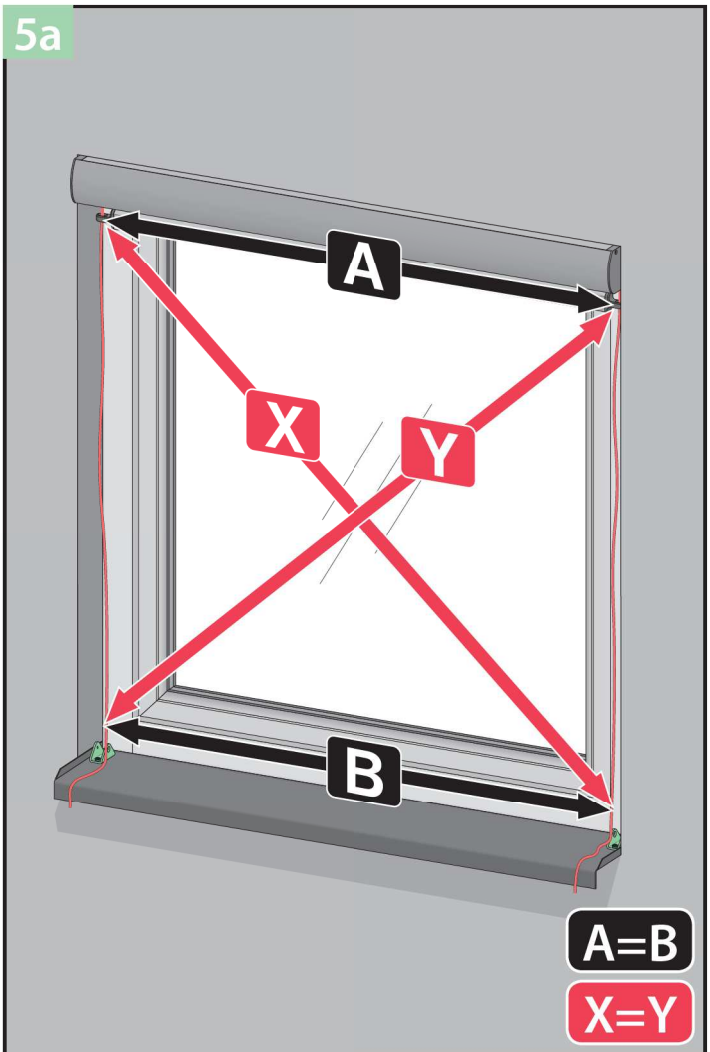

5b



5c

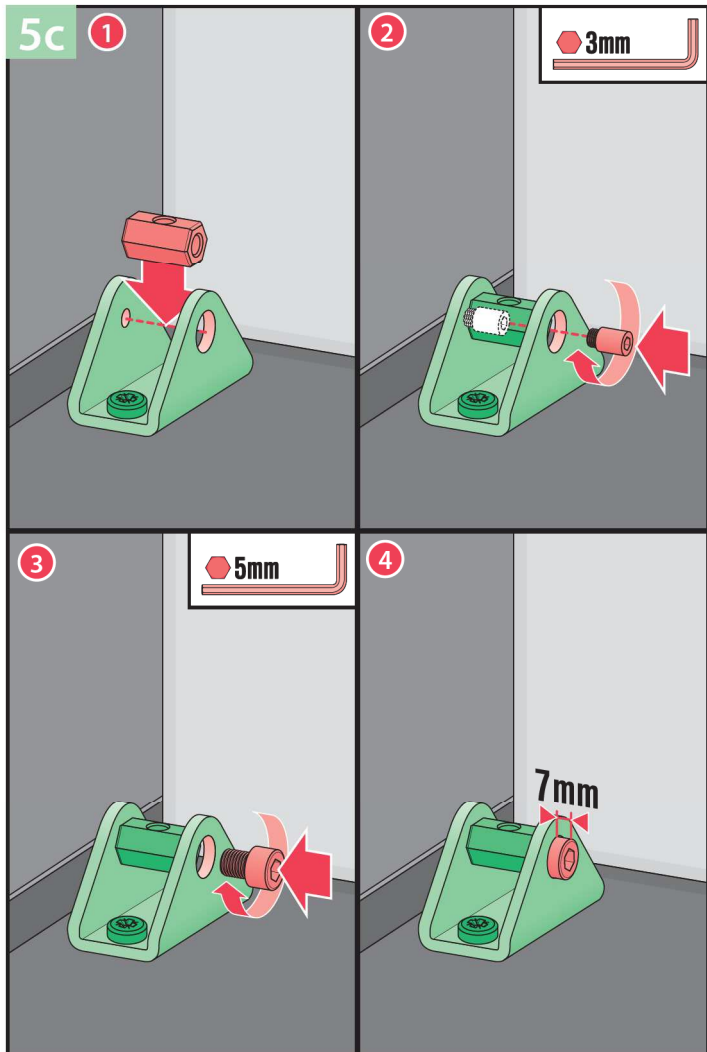

7

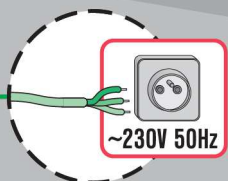
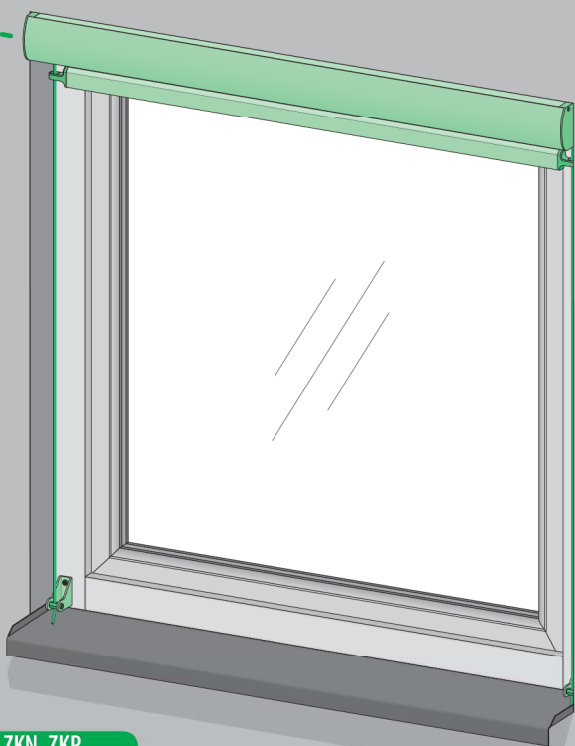

8

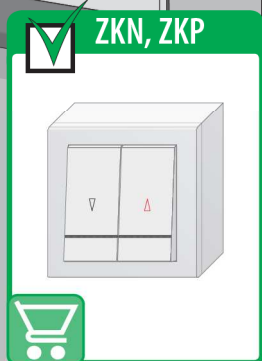
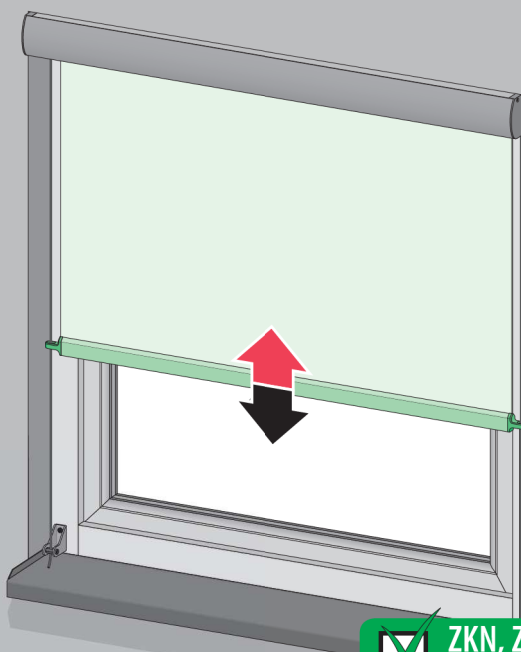

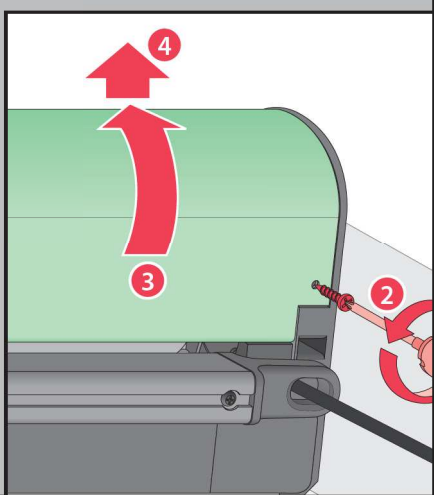
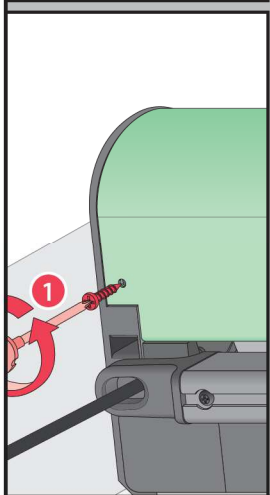
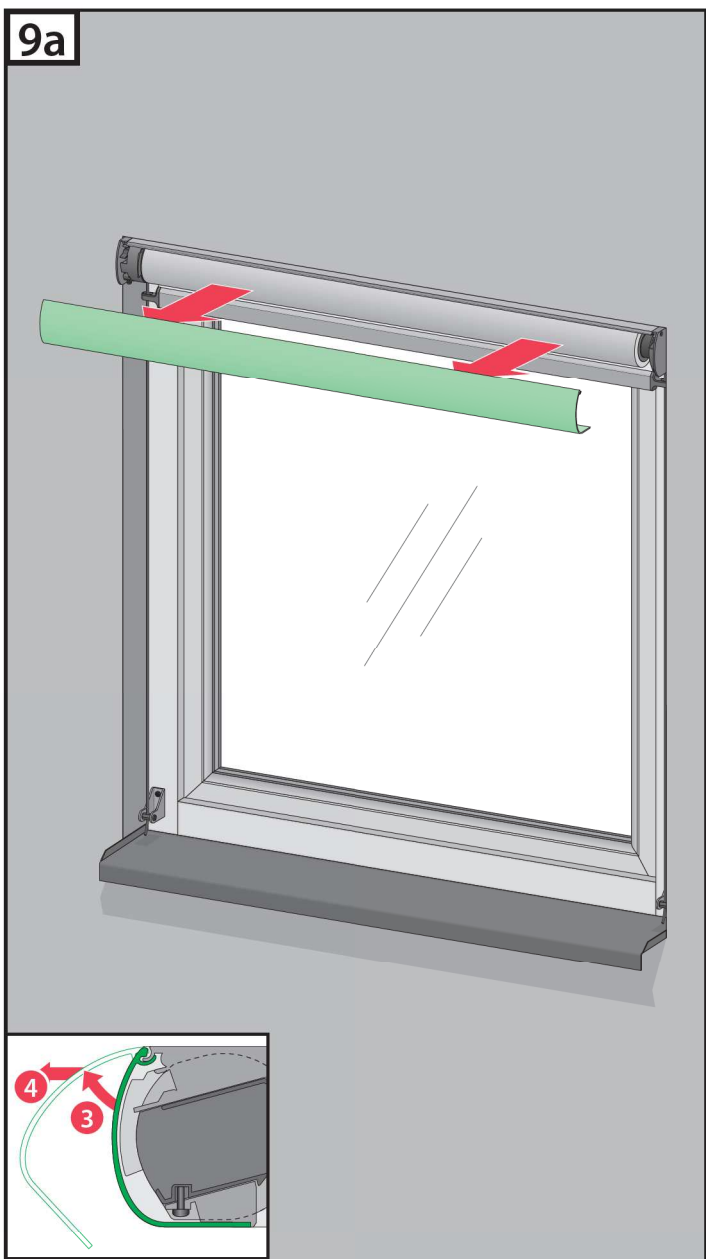
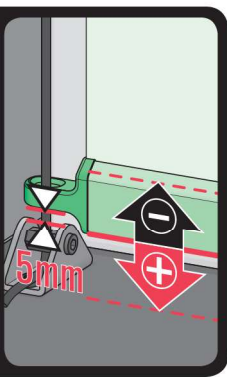
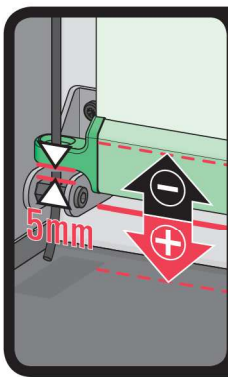
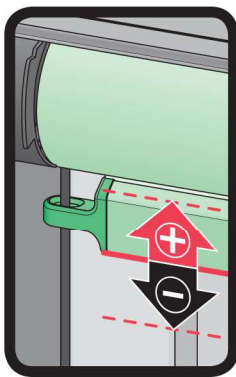

9b

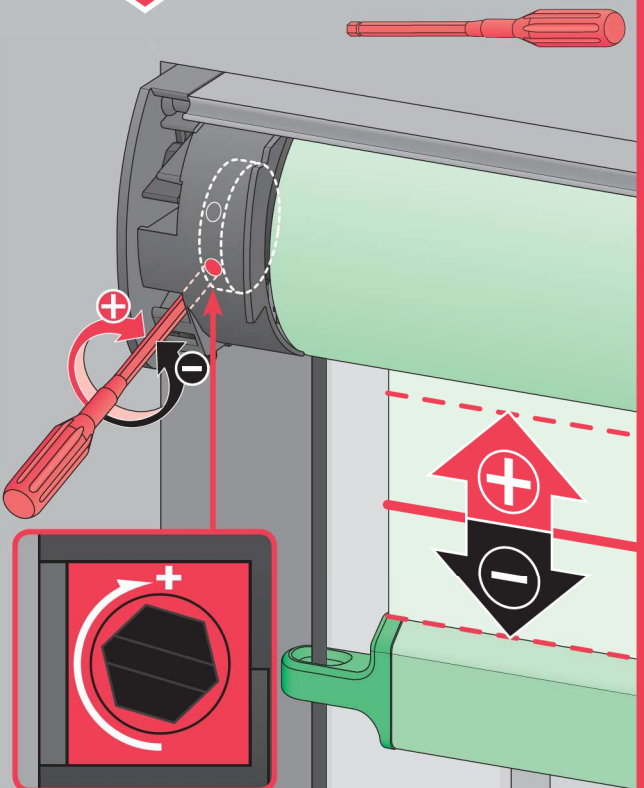
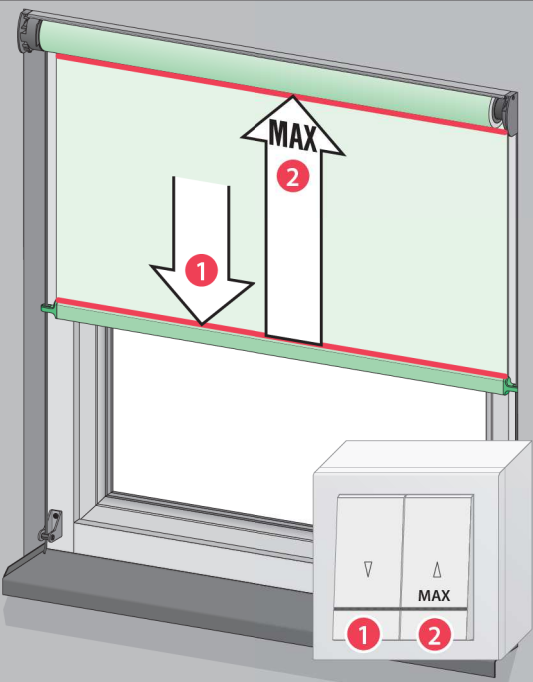

9c

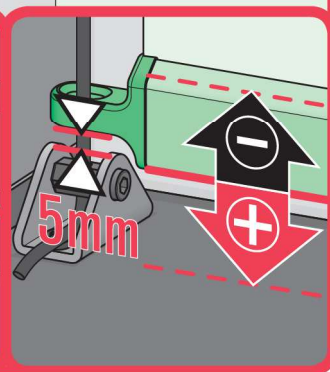
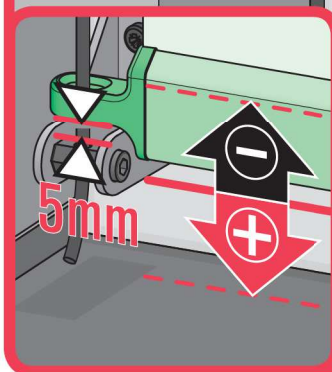
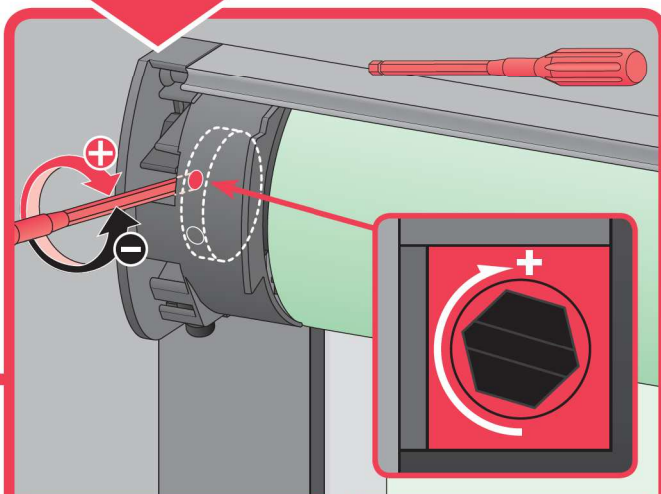
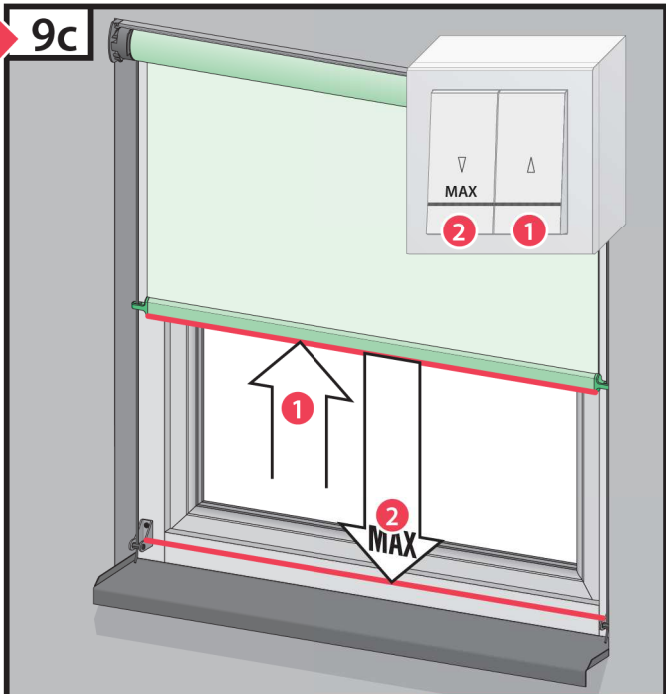

9d

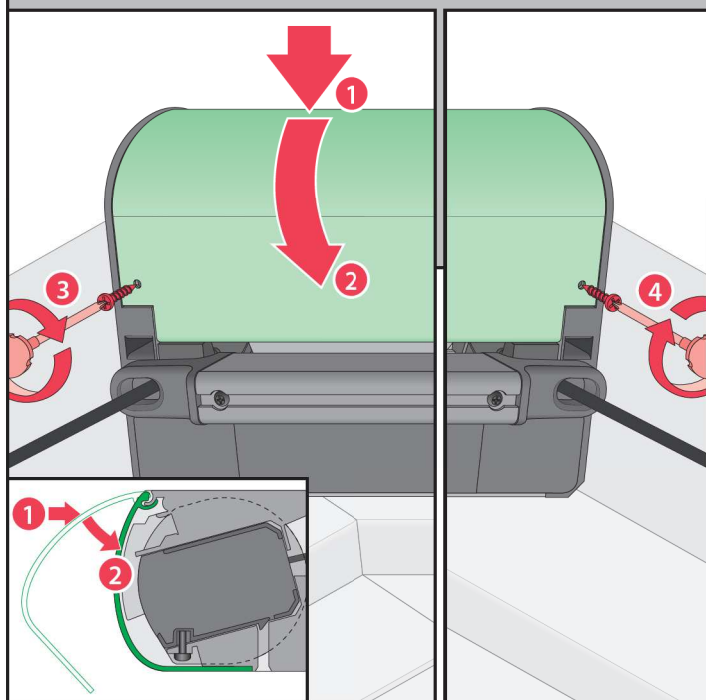
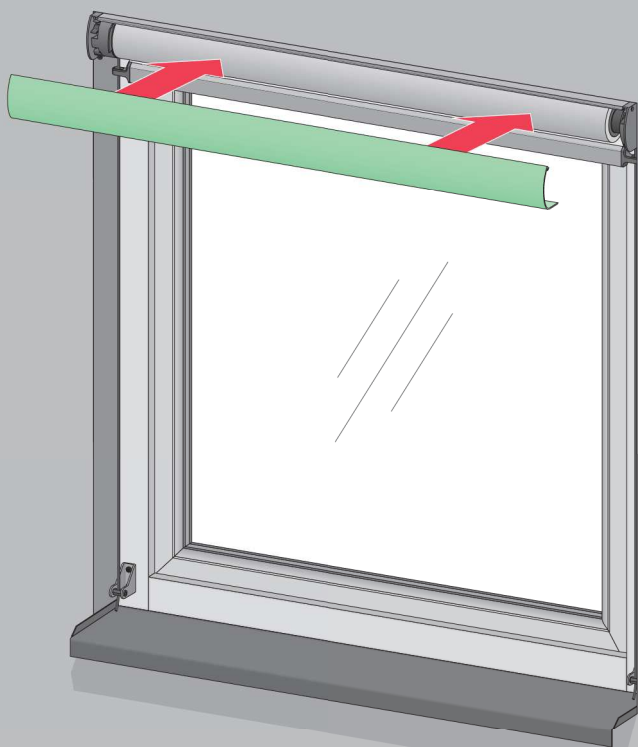

PL	Przed montażem należy zapoznać się z treścią instrukcji NC 9JH „INSTRUKCJA ORYGINALNA 2/3 Zasady montażu i użytkowania”.
1a	Wyciągnąć linki ze ślizgów belki dolnej markizy.
1b	Zdemontować klapę rewizyjną markizy.
1c	Zdemontować listwę maskującą.
1d	Odłączyć przewody zasilające.
1e, 1f	Zdemontować wkład markizy.
2a	Umieścić kasetę markizy w otworze okiennym.
2b	Wypoziomować a następnie przykręcić kasetę.
3, 3a, 3b	Zamontować wkład markizy.
3c	Podłączyć przewody zasilające.
3d	Zamontować listwę maskującą.
3e	Zamontować klapę rewizyjną.
4	Przeciągnąć linki przez otwór w ślizgach.
5	Dobrać odpowiednie uchwyty dolne (prawy/lewy).
5, 5a, 5b, 5c	Zamontować uchwyty dolne zachowując odpowiednie odległości.
5d	Naciągnąć linkę, zabezpieczyć śrubą, odciąć nadmiar linki.
6	Powtórzyć czynności 5a-5d dla drugiego uchwyty.
7	Podłączyć markizę do zasilania.
8	Sterować markizą za pomocą przełącznika.
9	W razie potrzeby przeprowadzić regulację pozycji krańcowych markizy.

EN	Before installation, it is compulsory to read the NC 9JH „ORIGINAL INSTRUCTIONS 2/3 Installation and user manual”.
1a	Remove strings from sliders in the bottom bar of the awning.
1b	Remove the awning inspection cover.
1c	Remove the cover strip.
1d	Disconnect power cables.
1e, 1f	Remove the awning insert.
2a	Place the awning cassette in the window opening.
2b	Level and then screw the cassette.
3, 3a, 3b	Install the awning insert.
3c	Connect power cables.
3d	Install the cover strip.
3e	Install the inspection cover.
4	Pull strings through the opening in sliders.
5	Select suitable bottom holders (right/left).
5, 5a, 5b, 5c	Install the bottom holders keeping appropriate distances.
5d	Tighten the string, secure with a screw and cut off its excess.
6	Repeat steps 5a-5d for the left second holder.
7	Connect the awning to the power supply.
8	Operate the awning using the switch.
9	If required, adjust the end positions of the awning.

CZ	Před montáží si pozorně přečtěte návod NC 9JH „ORIGINÁLNÍ NÁVOD 2/3 Pravidla pro instalaci a použití”.
1a	Vytáhněte lanka z úchyťů spodní lišty markýzy.
1b	Odmontujte revizní kryt markýzy.
1c	Odmontujte krycí lištu.
1d	Odpojte napájecí kabely.
1e, 1f	Odmontujte váleček markýzy.
2a	Umístěte kazetu markýzy do okenního otvoru.
2b	Vyrovnejte a následně přišroubujte kazetu.
3, 3a, 3b	Namontujte váleček markýzy.
3c	Připojte napájecí kabely.
3d	Namontujte krycí lištu.
3e	Namontujte revizní kryt.
4	Protáhněte lanka otvory v úchytech.
5	Vyberte příslušné spodní držáky (pravý/ levý).
5, 5a, 5b, 5c	Namontujte spodní držáky ve správných vzdálenostech.
5d	Natáhněte lanko, zajistěte ho šroubem a odstraňte přebytečnou část.
6	Zopakujte činnosti 5a-5d pro druhou stranu.
7	Připojte markýzu k napájení.
8	Ovládejte markýzu pomocí vypínače.
9	V případě potřeby proveďte regulaci koncových poloh markýzy.

0 [cm] 1 2 3 4 5 6 7 8 9 10 11 12 13 14 15 16 17 18 19 20

CZ	Výrobce ani prodejce nenesou žádnou odpovědnost za nedodržení příslušných platných zákonů, stavebních předpisů a bezpečnostních požadavků uživatelem výrobku, architektem, montážníkem nebo vlastníkem budovy.	NL	De fabrikant en verkoper zijn niet aansprakelijk voor gevolgen bij het niet opvolgen van toepasselijke wetten, bouwbesluiten en veiligheidsvoorschriften door de gebruiker van het product, de architect, de installateur of de eigenaar van het gebouw.
DE	Hersteller und Verkäufer übernehmen keine Haftung für Nichtbeachtung entsprechender Rechts- und Bauvorschriften sowie Sicherheitsanforderungen seitens Produktbenutzers, Architekten, Monteure oder Gebäudebesitzers.	PL	Producent i Sprzedawca nie ponosi żadnej odpowiedzialności za nieprzestrzeganie stosownych przepisów prawa, przepisów budowlanych i wymogów bezpieczeństwa przez użytkownika produktu, architekta, montażystę lub właściciela budynku.
ES	El fabricante y el vendedor no tienen ninguna responsabilidad por el incumplimiento de la ley vigente, normas de construcción y exigencias de seguridad por parte del usuario del producto, arquitecto, instalador o el propietario del edificio.	PT	O fabricante e o vendedor não tem nenhuma responsabilidade pelo o não cumprimento da lei, códigos de construção e as exigências de segurança por parte do usuário do produto, arquiteto, instalador ou proprietário do edifício.
FR	Le fabricant et le revendeur ne prend aucune responsabilité de ne pas respecter les lois applicables, les règlements sur les bâtiments et les exigences de sécurité par l'utilisateur du produit, l'architecte, l'installateur ou le propriétaire du bâtiment.	RO	Nici producătorul, nici distribuitorul nu își vor asuma niciun fel de răspundere pentru nerespectarea legilor în vigoare, a legilor din domeniul construcțiilor sau a măsurilor de siguranță impuse utilizatorilor produsului, arhitecților, montajorilor sau proprietarilor clădirii.
GB	Manufacturer and Seller shall bear no liability for failure to comply with the applicable laws, building codes and safety requirements by the user of the product, architect, fitter or owner of the building.	RU	В случае несоблюдения архитектором, монтажником или владельцем здания строительных правил и норм безопасности ответственность с производителя и продавца снимается.
HU	A Gyártó és a Forgalmazó nem vállal semmiféle felelősséget a vonatkozó törvényi, építési és biztonsági előírások termékfelhasználó, építész, beépítőmester vagy épülettulajdonos általi be nem tartásáért.	SK	Výrobca a predajca nenesú žiadnu zodpovednosť za nedodržanie príslušných ustanovení zákona, stavebných predpisov a bezpečnostných požiadaviek užívateľom výrobku, architektom, montérom alebo majiteľom objektu.
IT	Il Produttore e il Rivenditore non potranno essere ritenuti responsabili per il mancato rispetto, da parte dell'utente del prodotto, del progettista, dell'installatore o del proprietario dell'edificio, delle leggi vigenti, nonché dei regolamenti edilizi e di quelli		